

GRU A BANDIERA A MENSOLA CON BRACCIO IN CANALINA **MOD. CMM1**

Braccio rotante con cuscinetti a sfere. • Freno regolabile a nastro e carrello portaparanco. • Impianto elettrico.
 Carrello porta-paranco a spinta con cuscinetti di guida laterali. • Verniciatura epossidica: colori standard: Parti fisse RAL 5015 , parti mobili RAL 1023.
 • Marcatura CE secondo Direttiva Macchine 2006/42/CE.

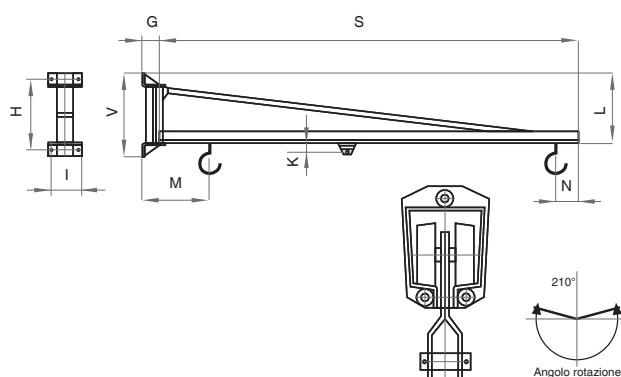

Varianti Pilastro fuori standard per installazione mensola Riferimento larghezza fronte del pilastro (mm)		
200/290	310/450	460/800

Tipo/Type	Portata KG	Sbraccio S (mt)	Pilastro Standard mm	Controstaffe e Tiranti Tipo	G	V	H	I	M	N	L	K
CMM1 125/3	125	3	300	A	205	647	507	330	641	96	480	60
CMM1 125/4	125	4	300	A	205	647	507	330	691	96	480	60
CMM1 125/5	125	5	300	A	205	827	692	330	771	96	660	60
CMM1 125/6	125	6	300	B	205	827	692	330	841	96	660	60
CMM1 125/7	125	7	300	D	200	977	842	330	936	96	810	60
CMM1 125/8	125	8	300	D	200	977	842	330	971	96	810	60
CMM1 250/3	250	3	300	A	205	827	692	330	641	96	660	60
CMM1 250/4	250	4	300	B	205	827	692	330	691	96	660	60
CMM1 250/5	250	5	300	B	200	977	842	330	791	96	810	60
CMM1 250/6	250	6	300	B	200	977	842	330	865	96	810	60
CMM1 250/7	250	7	300	C	195	977	842	330	956	96	810	60
CMM1 250/8	250	8	350	E	170	1207	1075	380	1030	120	1040	90
CMM1 500/3	500	3	300	B	200	977	842	330	690	120	810	90
CMM1 500/4	500	4	300	B	200	977	842	330	735	120	810	90
CMM1 500/5	500	5	300	C	195	977	842	330	860	120	810	90
CMM1 500/6	500	6	350	C	170	1207	1075	380	910	120	1040	90
CMM1 500/7	500	7	350	E	170	1207	1075	380	985	120	1040	90
CMM1 500/8	500	8	350	F	170	1207	1075	380	1100	160	1040	80
CMM1 1000/3	1000	3	350	B	195	977	845	380	720	160	810	80
CMM1 1000/4	1000	4	350	C	170	1207	1075	380	745	160	1040	80
CMM1 1000/5	1000	5	350	E	170	1207	1075	380	900	160	1040	80
CMM1 1000/6	1000	6	350	E	170	1207	1075	380	1056	160	1040	80
CMM1 1000/7	1000	7	350	E	170	1207	1075	380	1120	160	1040	80
CMM1 1000/8	1000	8	350	G	170	1207	1075	380	1230	160	1040	80