

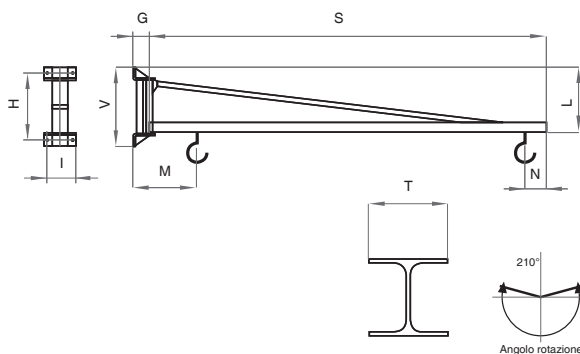

GRU A BANDIERA A MENSOLA CON BRACCIO IN TRAVE TIRANTATA **MOD. CMM2**

Braccio rotante con cuscinetti a sfere. • Freno regolabile a nastro. • Impianto elettrico
Verniciatura epossidica: colori standard: Parti fisse RAL 5015, parti mobili RAL 1023. • Marcatura CE secondo Direttiva Macchine 2006/42/CE



Varianti Pilastro fuori standard per installazione mensola

200/290	310/450	460/800
---------	---------	---------

Tipo/Type	Portata KG	Sbraccio S (mt)	Pilastro Standard mm	Controstaffe e Tiranti Tipo	G	V	H	I	M	N	L	T
CMM2 250/3	250	3	300	A	205	827	692	330	630	135	660	100
CMM2 250/4	250	4	300	B	205	827	692	330	630	135	660	100
CMM2 250/5	250	5	300	B	200	977	842	330	675	135	810	100
CMM2 250/6	250	6	300	B	200	977	842	330	375	135	810	100
CMM2 250/7	250	7	300	C	195	977	842	330	370	135	810	120
CMM2 250/8	250	8	350	E	170	1207	1075	380	720	135	1040	120
CMM2 250/9	250	9	350	F	195	1207	1075	380	720	135	1040	140
CMM2 500/3	500	3	300	B	200	977	842	330	682	140	810	100
CMM2 500/4	500	4	300	B	200	977	842	330	682	140	810	120
CMM2 500/5	500	5	300	C	195	977	842	330	677	140	810	120
CMM2 500/6	500	6	350	C	170	1207	1075	380	727	140	1040	120
CMM2 500/7	500	7	350	E	170	1207	1075	380	777	140	1040	140
CMM2 500/8	500	8	350	F	170	1207	1075	380	777	140	1040	140
CMM2 500/9	500	9	350	G	195	1207	1075	380	777	140	1040	180
CMM2 1000/3	1000	3	350	B	195	977	845	380	691	154	810	140
CMM2 1000/4	1000	4	350	C	170	1207	1075	380	741	154	1040	140
CMM2 1000/5	1000	5	350	E	170	1207	1075	380	791	154	1040	160
CMM2 1000/6	1000	6	350	E	170	1207	1075	380	816	154	1040	160
CMM2 1000/7	1000	7	350	E	170	1207	1075	380	816	154	1040	160
CMM2 1000/8	1000	8	350	G	170	1207	1075	380	816	154	1040	180
CMM2 1000/9	1000	9	350	H	170	1207	1075	380	816	154	1040	200
CMM2 2000/3	2000	3	350	E	195	1207	1075	380	691	180	1040	140
CMM2 2000/4	2000	4	350	F	195	1207	1075	380	741	180	1040	160
CMM2 2000/5	2000	5	350	G	195	1207	1075	380	791	180	1040	180
CMM2 2000/6	2000	6	350	H	195	1207	1075	380	816	180	1040	200
CMM2 2000/7	2000	7	350	L	195	1207	1075	380	816	180	1040	240